

TYPE EVCP-0100

E

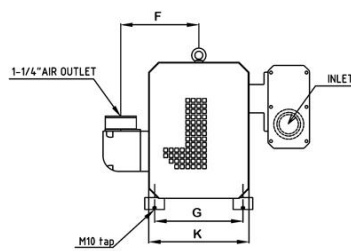

Capacity curve

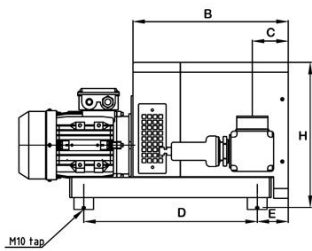
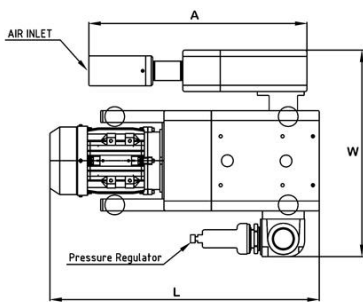
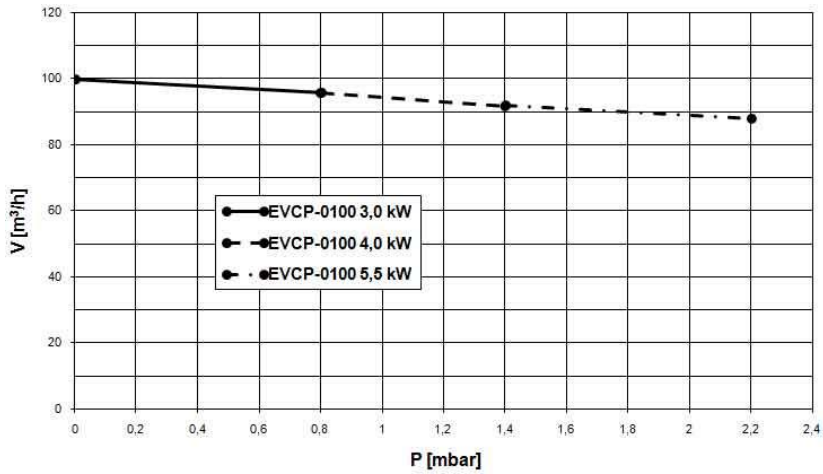

Dimensions	L	W	H	A	B	C	D	E	F	G	K
EVCP-0100 (3 / 4 / 5,5 kW)	683 / 731 / 763	525	373	553	394	91	440	79	198	224	254

TYPE EVCP-0100

E

Technical Data		TYPE EVCP-0100	
		50 Hz	60 Hz
Pressure flow rate	m ³ /h	100	120
Maximum pressure cont.	bar	0,8/1,4/2,2	1,4/2,2
Motor power	kW	3/4/5,5	4,8/6,5
Nominal speed	rpm	2850	3450
Noise level	dB(A)	81	83
Oil filling gear housing	ltr	0,5	0,5
Weight	kg	108/120/140	135/150
Admissible ambient temp.	°C	5 to 40	5 to 40
Connection	Inlet	G(BSP)	1½"
	Outlet	G(BSP)	1½"

Ordering Information	TYPE EVCP-0100	
	50 Hz	60 Hz
Three phase motor 400V, 50Hz (IEC) / 3,0 kW / 0,8 bar 400V, 50Hz (IEC) / 4,0 kW / 1,4 bar 400V, 50Hz (IEC) / 5,5 kW / 2,2 bar 400V, 60Hz (IEC) / 4,8 kW / 1,4 bar 400V, 60Hz (IEC) / 6,5 kW / 2,2 bar	612.001 612.002 612.003	612.005 612.006
Other Voltages/Frequencies	Upon request	
Pressure regulate valve	612.010	
Inlet damper	612.011	
Gasket set	612.012	
Maintenance kit	612.013	
Compressor module	612.014	

TYPE EVCP-0150

E



Capacity curve

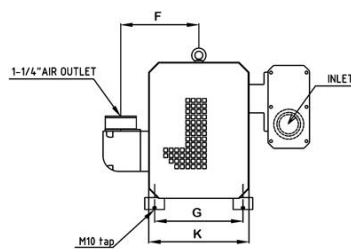
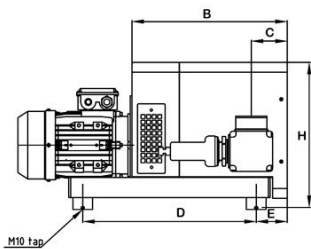
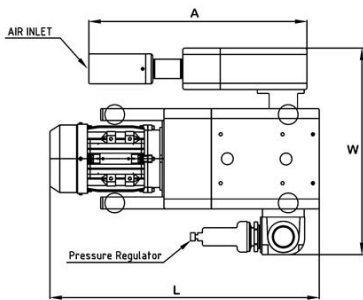
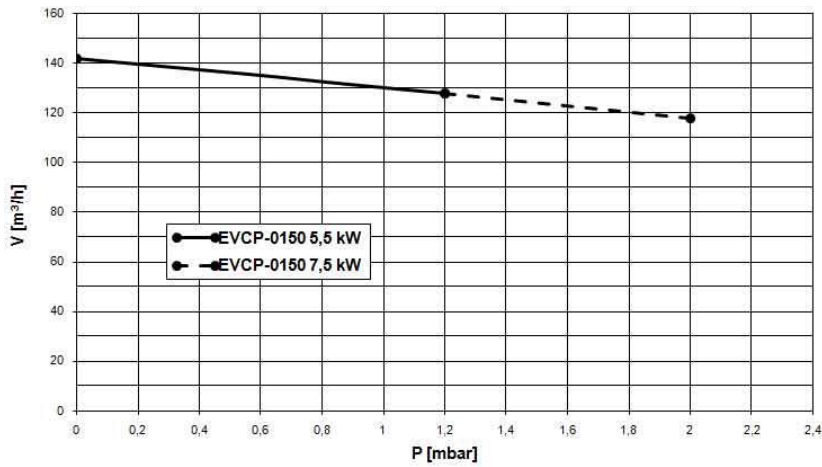

Dimensions	L	W	H	A	B	C	D	E	G	K
EVCP-0150 (5,5 / 7,5 kW)	763 / 793	527	368	553	424	91	440	79	224	254

TYPE EVCP-0150

E

Technical Data		TYPE EVCP-0150	
		50 Hz	60 Hz
Pressure flow rate	m ³ /h	142	170
Maximum pressure cont.	bar	1,2/2,0	1,0/2,0
Motor power	kW	5,5/7,5	6,5/9,0
Nominal speed	rpm	2850	3450
Noise level	dB(A)	83	85
Oil filling gear housing	ltr	0,5	0,5
Weight	kg	155/165	165/175
Admissible ambient temp.	°C	5 to 40	5 to 40
Connection	Inlet	G(BSP)	1½"
	Outlet	G(BSP)	1½"

Ordering Information	TYPE EVCP-0150	
	50 Hz	60 Hz
Three phase motor 400V, 50Hz (IEC) / 5,5 kW / 1,2 bar 400V, 50Hz (IEC) / 7,5 kW / 2,0 bar 400V, 60Hz (IEC) / 6,5 kW / 1,0 bar 400V, 60Hz (IEC) / 9,0 kW / 2,0 bar	613.001 613.002	613.005 613.006
Other Voltages/Frequencies	Upon request	
Pressure regulate valve	613.010	
Inlet damper	613.011	
Gasket set	613.012	
Maintenance kit	613.013	
Compressor module	613.014	

TYPE EVCP-0250

E



Capacity curve

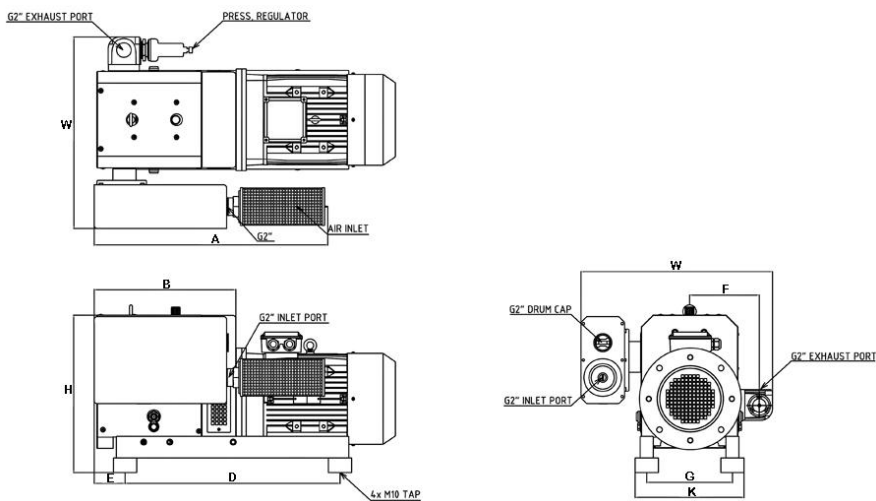
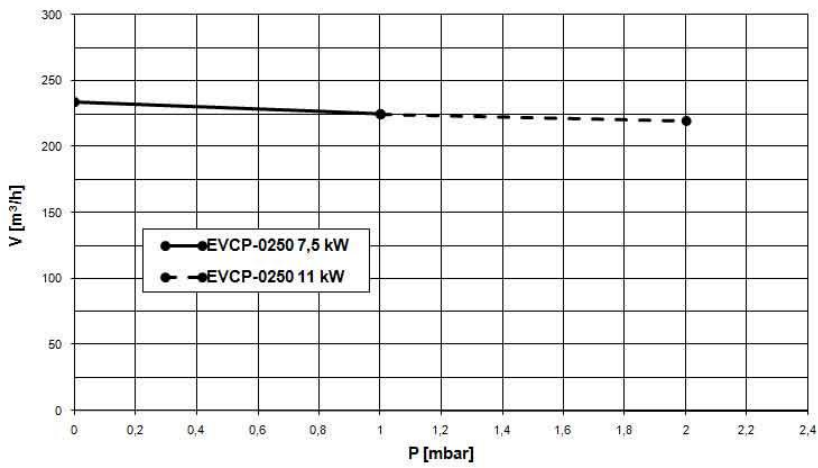

Dimensions	W	H	A	B	D	E	F	G	K
EVCP-0250	659	542	804	488	740	107	260	295	375

TYPE EVCP-0250

E

Technical Data		TYPE EVCP-0250	
		50 Hz	60 Hz
Pressure flow rate	m ³ /h	234	282
Maximum pressure cont.	bar	1,0/2,0	0,8/1,8/2,2
Motor power	kW	7,5/11	9/13/18
Nominal speed	rpm	2850	3450
Noise level	dB(A)	83	85
Oil filling gear housing	ltr	0,85	0,85
Weight	kg	220/247	240/267/285
Admissible ambient temp.	°C	5 to 40	5 to 40
Connection	Inlet	G(BSP)	2"
	Outlet	G(BSP)	2"

Ordering Information	TYPE EVCP-0250	
	50 Hz	60 Hz
Three phase motor 400V, 50Hz (IEC) / 7,5 kW / 1,0 bar 400V, 50Hz (IEC) / 11 kW / 2,0 bar 400V, 60Hz (IEC) / 9 kW / 0,8 bar 400V, 60Hz (IEC) / 13 kW / 1,8 bar 400V, 60Hz (IEC) / 18 kW / 2,2 bar	614.001 614.002	614.005 614.006 614.007
Other Voltages/Frequencies	Upon request	
Pressure regulate valve	614.010	
Inlet damper	614.011	
Gasket set	614.012	
Maintenance kit	614.013	
Compressor module	614.014	

TYPE EVCP-0300

E



Capacity curve

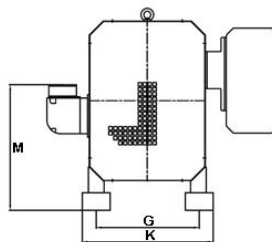
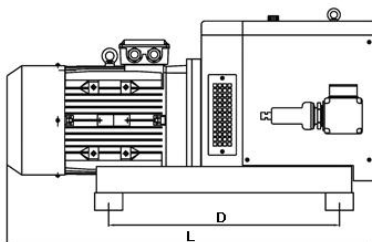
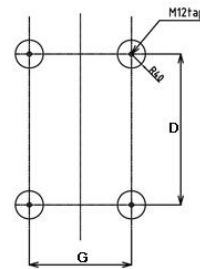
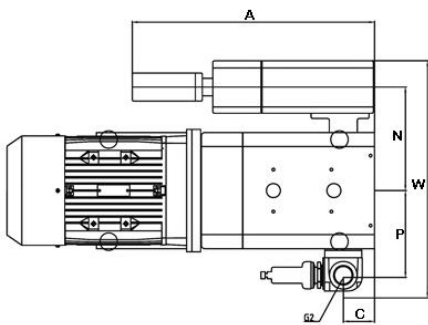
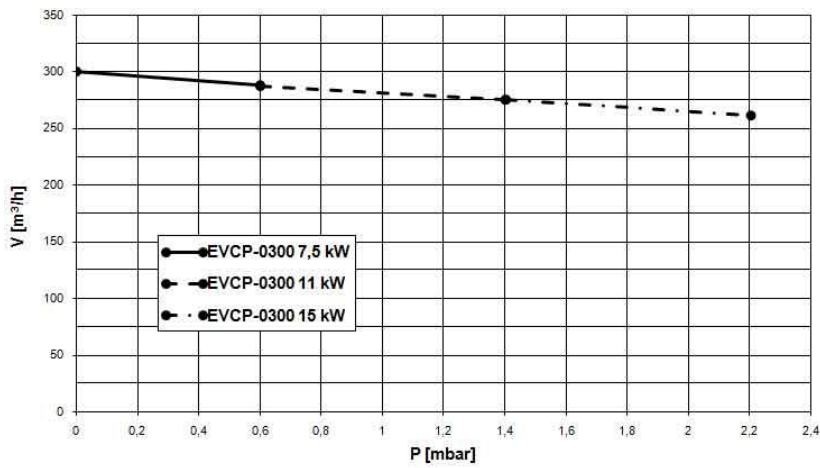

Dimensions	L	W	A	C	D	G	K	M	N	P
EVCP-0300 (7,5 / 11 / 15 kW)	By motor size	680	695	89	660	295	375	410	296	250

TYPE EVCP-0300

E

Technical Data		TYPE EVCP-0300	
		50 Hz	60 Hz
Pressure flow rate	m ³ /h	300	360
Maximum pressure cont.	bar	0,6/1,4/2,2	1,2/2,2
Motor power	kW	7,5/11/15	13/18
Nominal speed	rpm	2850	3450
Noise level	dB(A)	83	85
Oil filling gear housing	ltr	0,85	0,85
Weight	kg	230/256/290	276/294
Admissible ambient temp.	°C	5 to 40	5 to 40
Connection	Inlet	G(BSP)	2"
	Outlet	G(BSP)	2"

Ordering Information	TYPE EVCP-0300	
	50 Hz	60 Hz
Three phase motor 400V, 50Hz (IEC) / 7,5 kW / 0,6 bar 400V, 50Hz (IEC) / 11 kW / 1,4 bar 400V, 50Hz (IEC) / 15 kW / 2,2 bar 400V, 60Hz (IEC) / 13 kW / 1,2 bar 400V, 60Hz (IEC) / 18 kW / 2,2 bar	615.001 615.002 615.003	615.005 615.006
Other Voltages/Frequencies	Upon request	
Pressure regulate valve	615.010	
Inlet damper	615.011	
Gasket set	615.012	
Maintenance kit	615.013	
Compressor module	615.014	

TYPE EVCP-0400

E



Capacity curve

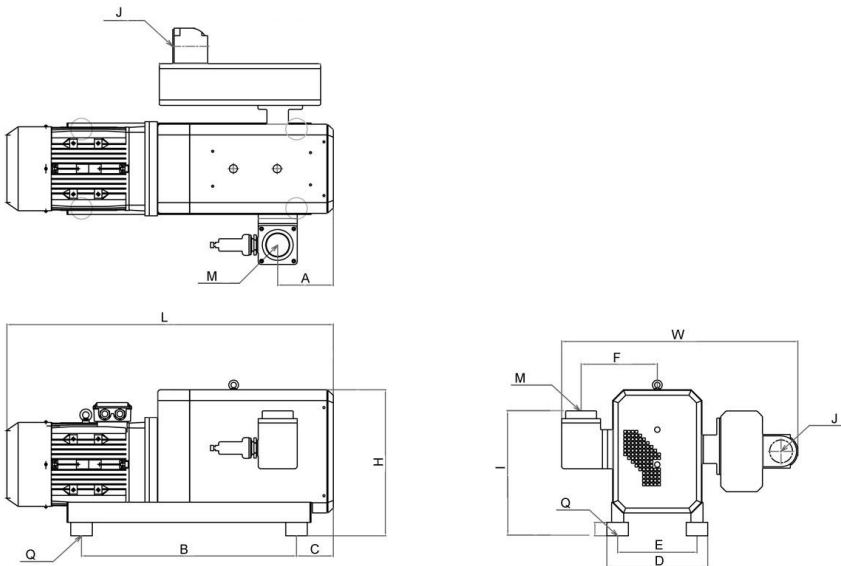
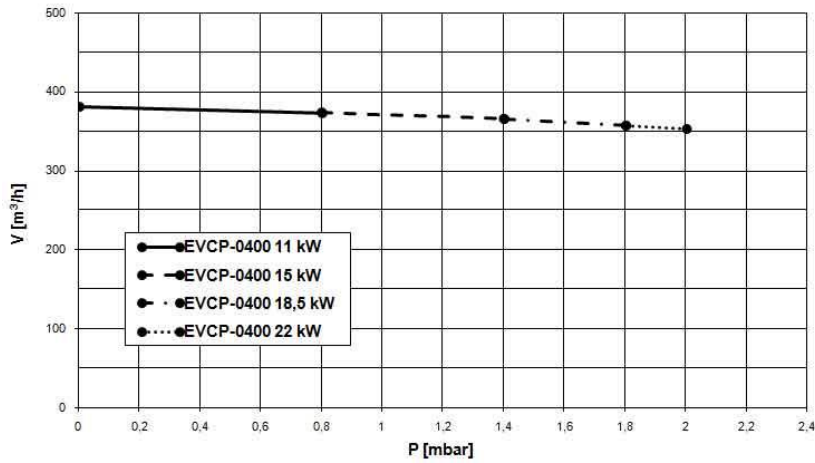

Dimensions	L	W	H	B	C	D	E	F	A	I	J	M	Q
EVCP-0400 (15 to 22/[30]kW)	1211/[1237]	899	544	800	133	372	292	282	205	468	3"	3"	4xM12

TYPE EVCP-0400

E

Technical Data		TYPE EVCP-0400	
		50 Hz	60 Hz
Pressure flow rate	m ³ /h	400	480
Maximum pressure cont.	bar	0,8/1,4/1,8/2,0	0,6/1,2/1,6/2,0
Motor power	kW	11/15/18,5/22	13/18/22/26
Nominal speed	rpm	2850	3450
Noise level	dB(A)	84	85
Oil filling gear housing	ltr	0,85	0,85
Weight	kg	383/403/423/450	403/423/450/470
Admissible ambient temp.	°C	5 to 40	5 to 40
Connection	Inlet	G(BSP)	3"
	Outlet	G(BSP)	3"

Ordering Information	TYPE EVCP-0400	
	50 Hz	60 Hz
Three phase motor		
400V, 50Hz (IEC) / 11 kW	616.001	
400V, 50Hz (IEC) / 15 kW	616.002	
400V, 50Hz (IEC) / 18,5 kW	616.003	
400V, 50Hz (IEC) / 22 kW	616.004	
400V, 60Hz (IEC) / 13 kW		616.005
400V, 60Hz (IEC) / 18 kW		616.006
400V, 60Hz (IEC) / 22 kW		616.007
400V, 60Hz (IEC) / 26 kW		616.008
Other Voltages/Frequencies	Upon request	
Pressure regulate valve	616.010	
Inlet damper	616.011	
Gasket set	616.012	
Maintenance kit	616.013	
Compressor module	616.014	

TYPE EVCP-0500

E



Capacity curve

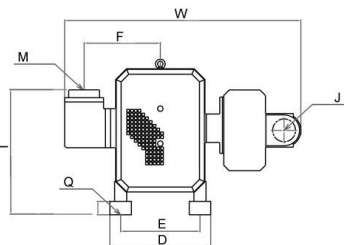
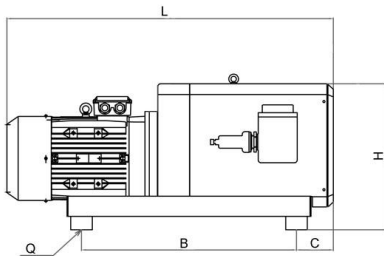
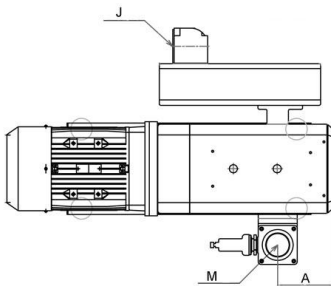
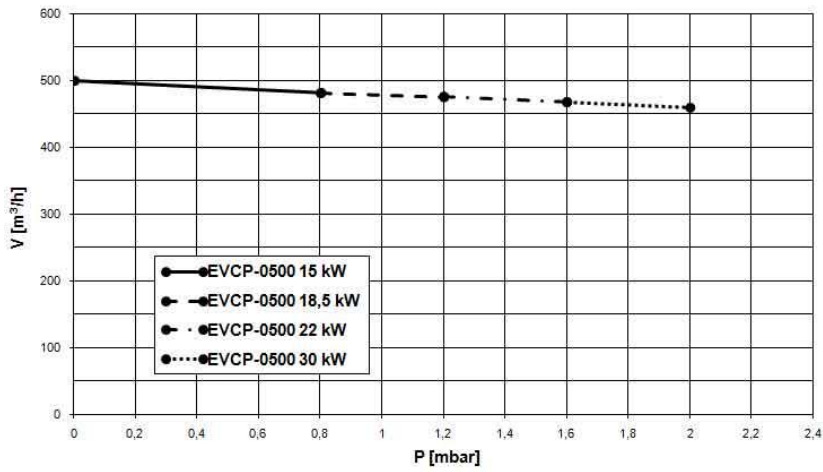

Dimensions	L	W	H	B	C	D	E	F	A	I	J	M	Q
EVCP-0500 15/18.5/22/30kW	1230/1230/1256[1237]	899	544[618]	800[1000]	152[148]	372	292	282	215	468[543]	3"	3"	4xM12

TYPE EVCP-0500

E

Technical Data		TYPE EVCP-0500	
		50 Hz	60 Hz
Pressure flow rate	m ³ /h	500	600
Maximum pressure cont.	bar	0,8/1,2/1,6/2,0	0,8/1,6/2,0
Motor power	kW	15/18,5/22/30	18/26/36
Nominal speed	rpm	2850	3450
Noise level	dB(A)	84	85
Oil filling gear housing	ltr	0,85	0,85
Weight	kg	418/438/465/525	438/485/555
Admissible ambient temp.	°C	5 to 40	5 to 40
Connection	Inlet	G(BSP)	3"
	Outlet	G(BSP)	3"

Ordering Information	TYPE EVCP-0500	
	50 Hz	60 Hz
Three phase motor		
400V, 50Hz (IEC) / 15 kW	617.001	
400V, 50Hz (IEC) / 18,5 kW	617.002	
400V, 50Hz (IEC) / 22 kW	617.003	
400V, 50Hz (IEC) / 30 kW	617.004	
400V, 60Hz (IEC) / 18 kW		617.005
400V, 60Hz (IEC) / 26 kW		617.006
400V, 60Hz (IEC) / 36 kW		617.007
Other Voltages/Frequencies	Upon request	
Pressure regulate valve	617.010	
Inlet damper	617.011	
Gasket set	617.012	
Maintenance kit	617.013	
Compressor module	617.014	